

HANGAR 9™

F-22 Raptor PTS™

ASSEMBLY MANUAL



Specifications

Wingspan (with droops and tip extensions).....	52 in (1320.8 mm)
Wingspan (without droops and tip extensions).....	47.9 in (1216.66 mm)
Length.....	50.3 in (1277.62 mm)
Wing Area (with droops and tip extensions).....	731 sq in (47.16 sq dm)
Wing Area (without droops and tip extensions).....	675 sq in (43.55 sq dm)
Weight.....	7.0–7.5 lb (3.18–3.40 kg)
Radio.....	JR® Sport 600X 6-channel system (installed)
Engine.....	Evolution® Engines Trainer Power System (installed)

Lockheed Martin and F-22 RAPTOR are either registered trademarks or trademarks of Lockheed Martin Corporation in the USA and/or other countries, used under license by Horizon Hobby, Inc.

Table of Contents

Introduction	3
Contents of Kit	3
UltraCote Covering Colors	4
Required Items	4
Optional Parts and Accessories	4
Additional Required Tools and Adhesives	4
Items for Optional Flaps	4
Warranty Period	5
Limited Warranty	5
Damage Limits	5
Safety Precautions	5
Questions, Assistance, and Repairs	6
Inspection or Repairs	6
Warranty Inspection and Repairs	6
Non-Warranty Repairs	6
Safety, Precautions, and Warnings	7
Before Starting Assembly	7
Using the Manual	7
Section 1: Charging the Batteries	8
Section 2: Landing Gear Installation	9
Section 3: Tail Installation	11
Section 4: Propeller Installation	14
Section 5: Wing Installation	16
Section 6: Centering the Control Surfaces	18
Section 7: Checking the Control Surface Directions	20
Section 8: Checking the Control Throw Amounts	22
Section 9: Adjusting the Throttle	23
Section 10: Balancing Your F-22 Raptor	24
Section 11: Flight Preparations	26
Section 12: Maintaining Your F-22 Raptor PTS	27
Section 13: Progressing With Your Flying Skills	28
Section 14: Adding Flap Servos	30
Glossary of Terms	33
2007 Official AMA National Model Aircraft Safety Code	34

Introduction

Sophisticated sensors, unmatched close-in dogfighting skills and undetectable at long range. The F-22 Raptor, the U.S. Air Force's newest aircraft, is the most advanced stealth fighter in aviation technology. With the F-22 Raptor PTS, beginners can learn to fly on a trainer that looks exciting. PTS™ stands for Progressive Trainer System—an airplane that will allow you to go from training to turning loops and rolls without upgrading or purchasing a new plane. This revolutionary trainer sports red plastic NACA droops and wing tip extensions that attach to the outer edge of the wing to provide extra stability. Once you've mastered the basics, remove the droops and change the settings on the flap system to move up to the next level and enjoy sport aerobatics. Progress from learning to fly to performing simple aerobatics with Hangar 9's F-22 Raptor PTS.

The F-22 Raptor PTS is part of Hangar 9's complete line of top-quality aircraft and accessories. Our Ready-To-Fly (RTF), Almost-Ready-to-Fly (ARF), Progressive Trainer System (PTS) and Plug-N-Play® (PNP®) trainer, performance and scale airplanes are engineered and crafted to exacting standards and feature the finest components and materials, such as our exclusive UltraCote® covering. Just as important, with every Hangar 9® product, you'll get the service and technical support you need to succeed.

Contents of Kit

Replacement Parts

- | | |
|------------|-------------------------------|
| A. HAN3826 | Wing Set |
| B. HAN3827 | Fuselage |
| C. HAN3828 | Stabilizer Set w/Elevator (2) |
| D. HAN3829 | Fin Set w/Rudders (2) |
| E. HAN3830 | Cowling |
| F. HAN3831 | Canopy |
| G. HAN3832 | Landing Gear Set Complete |

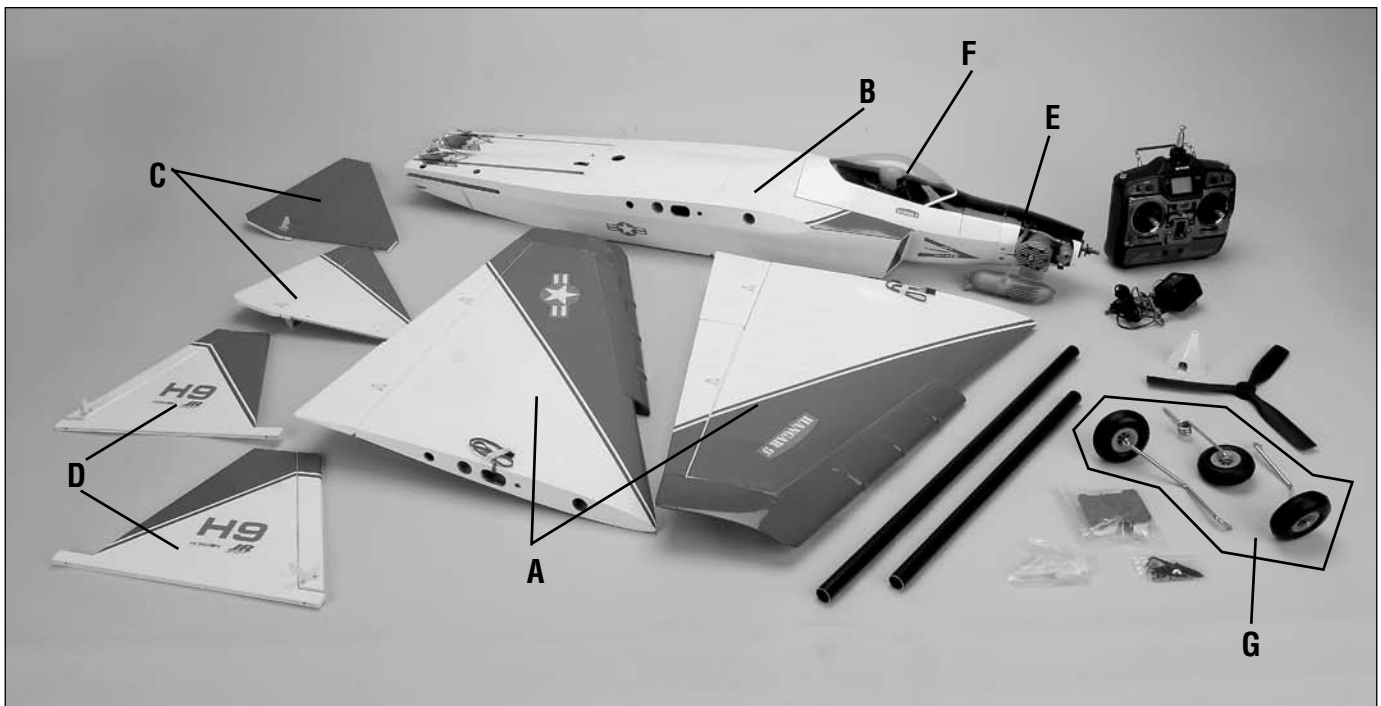

UltraCote® Covering Colors

- True Red HANU866
- Black HANU874
- White HANU870

Required Items

- Fuel (10%–15% nitro content)
 - Glow Plug Igniter with Charger (HAN7101)
 - Manual Fuel Pump (HAN118)
 - Glow Plug Wrench (HAN2510)
 - Glow Plug (HAN3001/3006)
- or
- Start-Up Field Pack (HANSTART)

Optional Parts and Accessories

- Field Mate Prebuilt Field Box (HAN117)
- Metered Glow Driver w/Ni-Cd and Charger (HAN7101)
- Manual Fuel Pump (HAN118)
- Aluminum Transmitter Case for Single Tx (HAN124)
- Long Reach Glow Plug Wrench (HAN2510)
- Transmitter Stand (HAN2525)
- Hangar 9 Straw Hat (HANP303)
- Mosfet Power Panel (HAN106)
- PowerPro 12V Starter (HAN161)
- Double Vision Fast Field Charger (HAN114)
- Digital Variable Load Voltmeter (HAN171)
- 2-Cycle Sport Glow Plug (HAN3001)
- Angle Pro Throw/Incidence Meter (HAN192)

Additional Required Tools and Adhesives

- Felt-tipped pen
- Adjustable wrench
- Phillips screwdriver
- Pliers
- Threadlock (PAAPT42)

Items for Optional Flaps

- Drill
- Drill bit: 1/16 in (1.5mm)
- 6-minute epoxy
- Hobby knife
- Razor saw
- Phillips screwdriver (small)
- Long Servo Arm (JRPA212) (2)
- Y-Harness (JSP98020)

Warranty Period

Exclusive Warranty- Horizon Hobby, Inc., (Horizon) warrants that the Products purchased (the "Product") will be free from defects in materials and workmanship at the date of purchase by the Purchaser.

Limited Warranty

(a) This warranty is limited to the original Purchaser ("Purchaser") and is not transferable. REPAIR OR REPLACEMENT AS PROVIDED UNDER THIS WARRANTY IS THE EXCLUSIVE REMEDY OF THE PURCHASER. This warranty covers only those Products purchased from an authorized Horizon dealer. Third party transactions are not covered by this warranty. Proof of purchase is required for warranty claims. Further, Horizon reserves the right to change or modify this warranty without notice and disclaims all other warranties, express or implied.

(b) Limitations- HORIZON MAKES NO WARRANTY OR REPRESENTATION, EXPRESS OR IMPLIED, ABOUT NON-INFRINGEMENT, MERCHANTABILITY OR FITNESS FOR A PARTICULAR PURPOSE OF THE PRODUCT. THE PURCHASER ACKNOWLEDGES THAT THEY ALONE HAVE DETERMINED THAT THE PRODUCT WILL SUITABLY MEET THE REQUIREMENTS OF THE PURCHASER'S INTENDED USE.

(c) Purchaser Remedy- Horizon's sole obligation hereunder shall be that Horizon will, at its option, (i) repair or (ii) replace, any Product determined by Horizon to be defective. In the event of a defect, these are the Purchaser's exclusive remedies. Horizon reserves the right to inspect any and all equipment involved in a warranty claim. Repair or replacement decisions are at the sole discretion of Horizon. This warranty does not cover cosmetic damage or damage due to acts of God, accident, misuse, abuse, negligence, commercial use, or modification of or to any part of the Product. This warranty does not cover damage due to improper installation, operation, maintenance, or attempted repair by anyone other than Horizon. Return of any goods by Purchaser must be approved in writing by Horizon before shipment.

Damage Limits

HORIZON SHALL NOT BE LIABLE FOR SPECIAL, INDIRECT OR CONSEQUENTIAL DAMAGES, LOSS OF PROFITS OR PRODUCTION OR COMMERCIAL LOSS IN ANY WAY CONNECTED WITH THE PRODUCT, WHETHER SUCH CLAIM IS BASED IN CONTRACT, WARRANTY, NEGLIGENCE, OR STRICT LIABILITY. Further, in no event shall the liability of Horizon exceed the individual price of the Product on which liability is asserted. As Horizon has no control over use, setup, final assembly, modification or misuse, no liability shall be assumed nor accepted for any resulting damage or injury. By the act of use, setup or assembly, the user accepts all resulting liability.

If you as the Purchaser or user are not prepared to accept the liability associated with the use of this Product, you are advised to return this Product immediately in new and unused condition to the place of purchase.

Law: These Terms are governed by Illinois law (without regard to conflict of law principals).

Safety Precautions

This is a sophisticated hobby Product and not a toy. It must be operated with caution and common sense and requires some basic mechanical ability. Failure to operate this Product in a safe and responsible manner could result in injury or damage to the Product or other property. This Product is not intended for use by children without direct adult supervision. The Product manual contains instructions for safety, operation and maintenance. It is essential to read and follow all the instructions and warnings in the manual, prior to assembly, setup or use, in order to operate correctly and avoid damage or injury.

Questions, Assistance, and Repairs

Your local hobby store and/or place of purchase cannot provide warranty support or repair. Once assembly, setup or use of the Product has been started, you must contact Horizon directly. This will enable Horizon to better answer your questions and service you in the event that you may need any assistance. For questions or assistance, please direct your email to productsupport@horizonhobby.com, or call 877.504.0233 toll free to speak to a service technician.

Inspection or Repairs

If this Product needs to be inspected or repaired, please call for a Return Merchandise Authorization (RMA). Pack the Product securely using a shipping carton. Please note that original boxes may be included, but are not designed to withstand the rigors of shipping without additional protection. Ship via a carrier that provides tracking and insurance for lost or damaged parcels, as **Horizon is not responsible for merchandise until it arrives and is accepted at our facility**. A Service Repair Request is available at www.horizonhobby.com on the "Support" tab. If you do not have internet access, please include a letter with your complete name, street address, email address and phone number where you can be reached during business days, your RMA number, a list of the included items, method of payment for any non-warranty expenses and a brief summary of the problem. Your original sales receipt must also be included for warranty consideration. Be sure your name, address, and RMA number are clearly written on the outside of the shipping carton.

Warranty Inspection and Repairs

To receive warranty service, you must include your original sales receipt verifying the proof-of-purchase date. Provided warranty conditions have been met, your Product will be repaired or replaced free of charge. Repair or replacement decisions are at the sole discretion of Horizon Hobby.

Non-Warranty Repairs

Should your repair not be covered by warranty the repair will be completed and payment will be required without notification or estimate of the expense unless the expense exceeds 50% of the retail purchase cost. By submitting the item for repair you are agreeing to payment of the repair without notification. Repair estimates are available upon request. You must include this request with your repair. Non-warranty repair estimates will be billed a minimum of ½ hour of labor. In addition you will be billed for return freight. Please advise us of your preferred method of payment. Horizon accepts money orders and cashiers checks, as well as Visa, MasterCard, American Express, and Discover cards. If you choose to pay by credit card, please include your credit card number and expiration date. Any repair left unpaid or unclaimed after 90 days will be considered abandoned and will be disposed of accordingly. **Please note: non-warranty repair is only available on electronics and model engines.**

Electronics and engines requiring inspection or repair should be shipped to the following address:

Horizon Service Center
4105 Fieldstone Road
Champaign, Illinois 61822

All other Products requiring warranty inspection or repair should be shipped to the following address:

Horizon Product Support
4105 Fieldstone Road
Champaign, Illinois 61822

Please call 877-504-0233 with any questions or concerns regarding this product or warranty.

Safety, Precautions, and Warnings

This model is controlled by a radio signal that is subject to interference from many sources outside your control. This interference can cause momentary loss of control so it is advisable to always keep a safe distance in all directions around your model, as this margin will help to avoid collisions or injury.

- Always operate your model in an open area away from cars, traffic, or people.
- Avoid operating your model in the street where injury or damage can occur.
- Never operate the model into the street or populated areas for any reason.
- Never operate your model with low transmitter batteries.
- Carefully follow the directions and warnings for this and any optional support equipment (chargers, rechargeable battery packs, etc.) that you use.
- Keep all chemicals, small parts and anything electrical out of the reach of children.
- Moisture causes damage to electronics. Avoid water exposure to all equipment not specifically designed and protected for this purpose.

Before Starting Assembly

Before beginning the assembly of the F-22 Raptor PTS, remove each part from its bag for inspection. Closely inspect the fuselage, wing panels, rudder, and stabilizer for damage. If you find any damaged or missing parts, contact the place of purchase.

If you find any wrinkles in the covering, use a heat gun or sealing iron to remove them. Use caution while working around areas where the colors overlap to prevent separating the colors.



HAN101 – Sealing Iron

**HAN141 – Sealing Iron
Sock**



HAN100 – Heat Gun

HAN150 – Covering Glove

Using the Manual

This manual is divided into sections to help make assembly easier to understand, and to provide breaks between each major section. In addition, check boxes have been placed next to each step to keep track of each step completed. Steps with a single box () are performed once, while steps with two boxes () indicate that the step will require repeating, such as for a right or left wing panel, two servos, etc. Remember to take your time and follow the directions.

Section 1: Charging the Batteries

Before starting the assembly of your F-22 Raptor PTS, open the radio box and read the included instructions. Directions on the features, specifications, controls, functions, charging, and other useful information is contained in this manual.

To charge the radio, you will need to remove the charger and follow the radio instructions. The charge lead for the receiver battery is located in the fuselage of your F-22 Raptor PTS.

□ Step 1

Slide the hatch-holding pin back and lift the hatch from the fuselage.



□ Step 2

Connect the charger lead from the charger to the lead coming from the switch harness as shown.

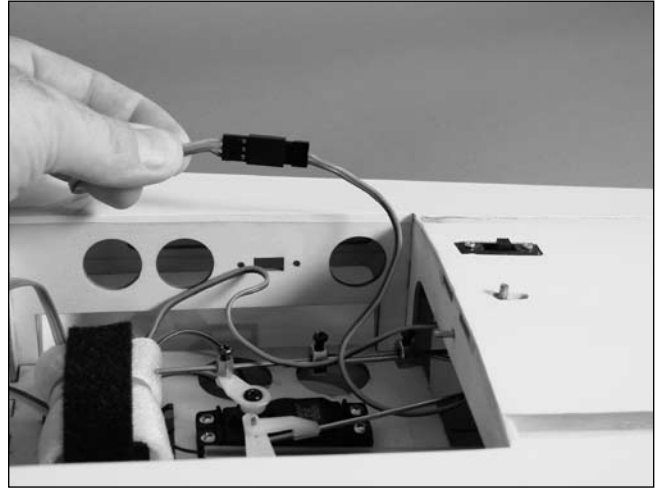

Note: There are two other leads for the aileron servos to plug into. The charger should not be connected to these plugs.

Section 2: Landing Gear Installation

Items Required

- Main landing gear (2)
- Nose landing gear
- Landing gear strap (4)
- #4 x 1/2" sheet metal screw (8)

Tools Required

- Phillips screwdriver
- Hex wrench (included in kit)
- Threadlocking compound

Step 1

Locate the landing gear, #4 x 1/2" sheet metal screws and the landing gear straps.

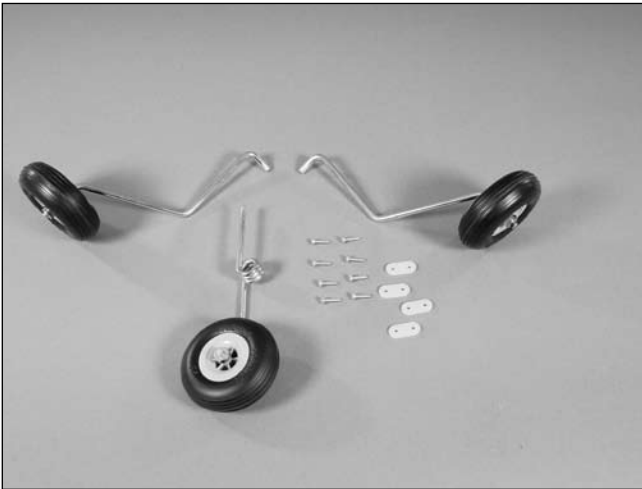

Step 2

Slide one of the main gears into the hole in the fuselage.



Step 3

Press the gear into the slot in the fuselage. Use two landing gear straps and four #4 x 1/2" sheet metal screws to secure the landing gear to the fuselage.



Step 4

Repeat Steps 2 and 3 to install the remaining main landing gear.

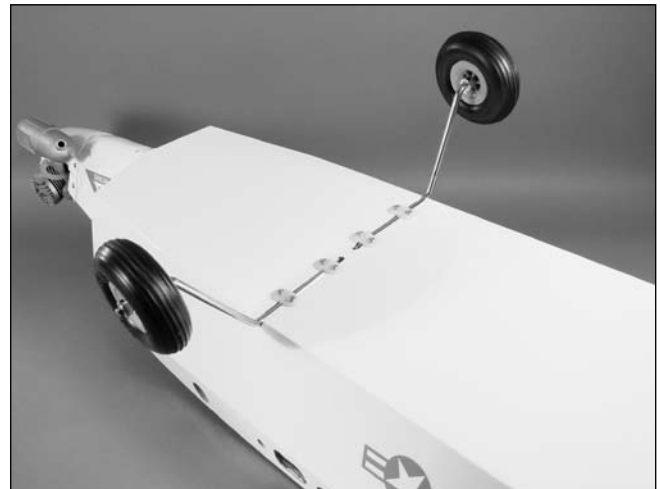

Section 2: Landing Gear Installation

□ Step 5

Slide the cockpit holding pin back and remove the cockpit from the fuselage.

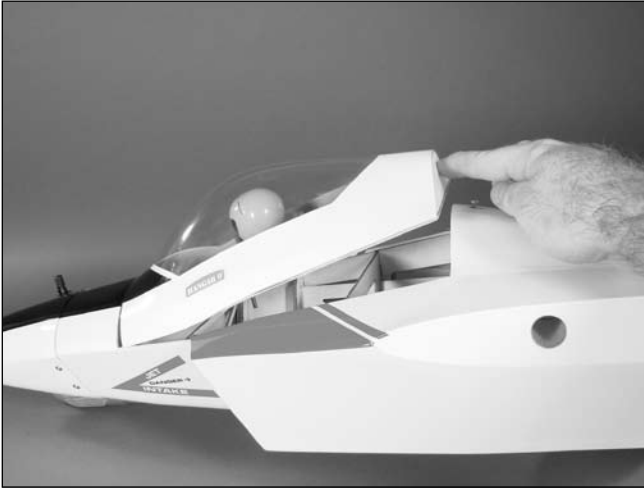

□ Step 6

Slide the nose gear into position from the bottom of the fuselage. Make sure the notch in the nose gear faces towards the rear of the fuselage.

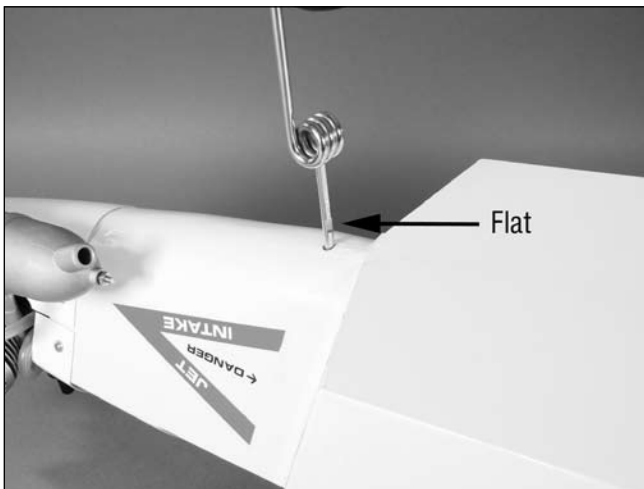

□ Step 7

Use the supplied hex wrench to tighten the screw in the steering arm onto the nose gear wire. The screw will rest on the flat area of the nose gear wire.

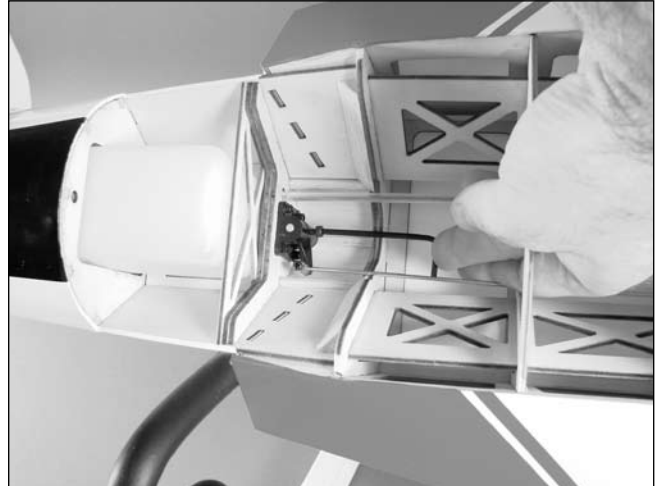

Hint: Apply a drop of threadlock to the screw before tightening it onto the nose gear wire.

Section 3: Tail Installation

Items Required

- Vertical stabilizer (left and right)
- Horizontal stabilizer (left and right)
- 4-40 x 3/4" hex head screw (4)
- #4 washer (silver) (4)
- 4-40 x 1" hex head screw (4)
- #4 washer (black) (4)

Tools Required

- Hex wrench (located in kit)

Step 1

Locate the vertical stabilizers, horizontal stabilizers, 4-40 x 3/4" hex head screws, #4 silver washers, 4-40 x 1" hex head screws and #4 black washers.

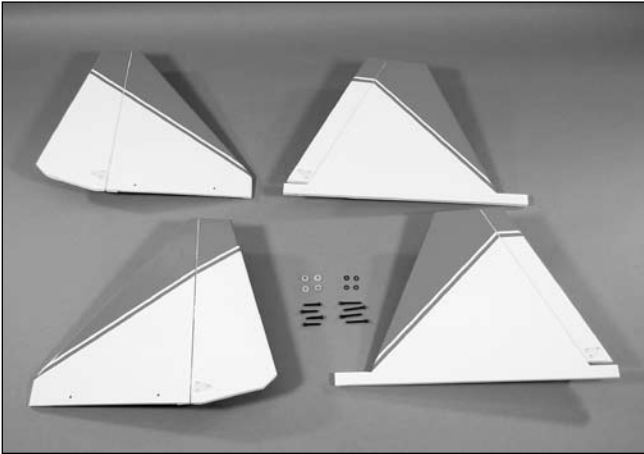

Step 2

Slide one of the horizontal stabilizers into the slot in the fuselage.



Step 3

Slide a #4 silver washer onto a 4-40 x 3/4" hex head screw, then thread the screw into the fuselage. Use two 4-40 x 3/4" screws and two #4 silver washers to secure the horizontal stabilizer into position.

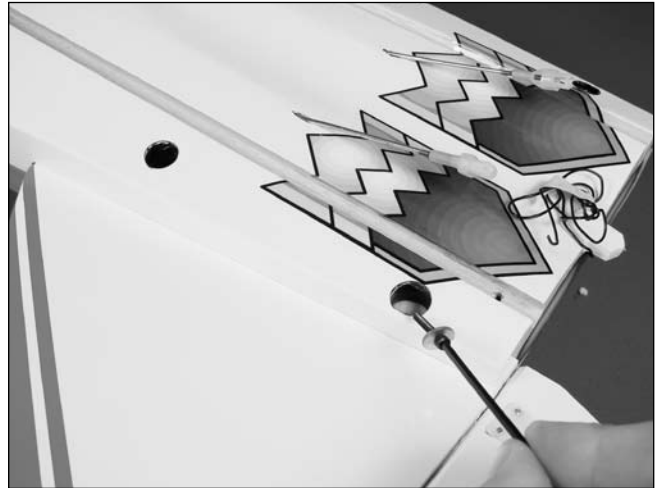

Section 3: Tail Installation

□ □ Step 4

Slide the clevis retainer back on the clevis. Attach the clevis to the control horn, and then slide the clevis retainer back onto the clevis to secure the clevis to the control horn.

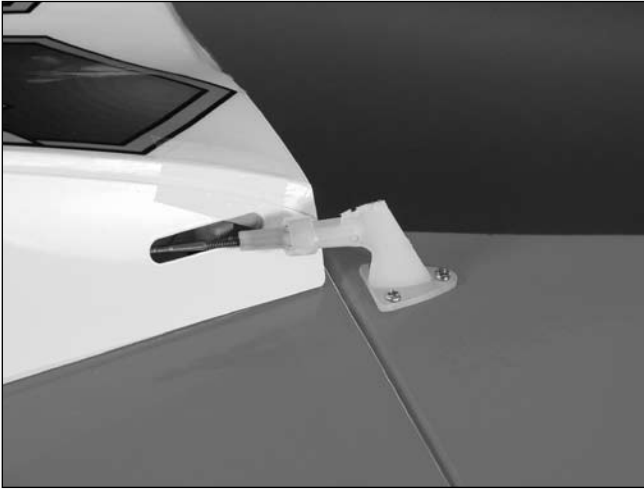

□ □ Step 5

Repeat Steps 2 through 4 to secure the remaining horizontal stabilizer to the fuselage.



□ □ Step 6

Check the screws on the wheel collars holding the two elevator linkages together. These screws must be tight before flying your aircraft.

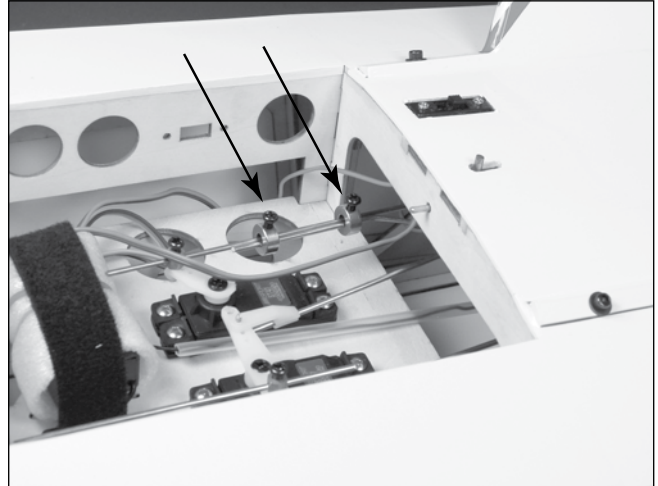

□ □ Step 7

Slide the vertical stabilizer into the slot in the fuselage. Apply a drop of threadlock to a 4-40 x 1" hex head screw. Slide a #4 black washer onto the screw. Use two 4-40 x 1" hex head screws and two #4 black washers to secure the vertical stabilizer to the fuselage.



Section 3: Tail Installation

Step 8

Slide the clevis retainer back on the clevis. Attach the clevis to the outer hole of the control horn, and then slide the clevis retainer back onto the clevis to secure the clevis to the control horn.

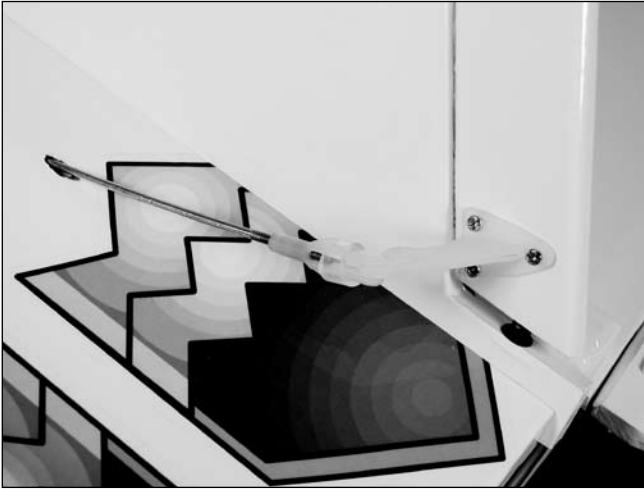

Step 9

Repeat Steps 7 and 8 to install the remaining vertical stabilizer.



Section 4: Propeller Installation

Items Required

- Spinner w/backplate
- Propeller
- Spinner adapter w/screw

Tools Required

- Adjustable wrench
- Hex wrench (included in kit)

Step 1

Locate the spinner, spinner backplate, propeller, propeller adapter and adapter screw.



Step 2

Remove the propeller nut and washer from the engine.



Step 3

Slide the spinner backplate onto the engine shaft



Step 4

Slide the propeller onto the engine shaft.



Section 4: Propeller Installation

□ Step 5

Slide the washer onto the engine shaft and then thread the spinner adapter onto the engine shaft. Rotate the propeller clockwise so it is resting against the lugs of the spinner backplate. Finger-tighten the adapter.



Note: You will not use the pre-installed nut from your engine for this application. Make sure to save the nut somewhere in case you use the engine from your F-22 Raptor in a future project.

□ Step 6

Use an adjustable wrench to tighten the propeller nut. Make sure the propeller remains against the lugs on the spinner backplate.



Important: DO NOT use pliers, as the nut will not be tight enough and could come loose.

Note: It is suggested to read the engine instructions included with your F-22 Raptor PTS at this time to learn more on the care and operation of your Evolution® engine.

□ Step 7

Locate the spinner cone and position it onto the spinner back plate. The cone will key to the backplate with no gap between the backplate and cone.



□ Step 8

Slide the adapter screw through the hole in the end of the spinner and thread it into the adapter. Use the included hex wrench to tighten the screw. Do not over-tighten the screw which could possibly deform the spinner.



Section 5: Wing Installation

Items Required

- Wing panel (left and right)
- Wing tube (short)
- Wing tube (long)
- 1/4-20 x 2 1/2" nylon wing bolt (2)

□ Step 1

Locate the wing panels, wing tubes and nylon bolts.



□ Step 2

Temporarily attach each flap linkage to the rear flap position tab. With the linkage in the up position attach the clevis to the control horn. The flap should be in the full up neutral position. If it isn't, adjust the threaded clevis until it is.

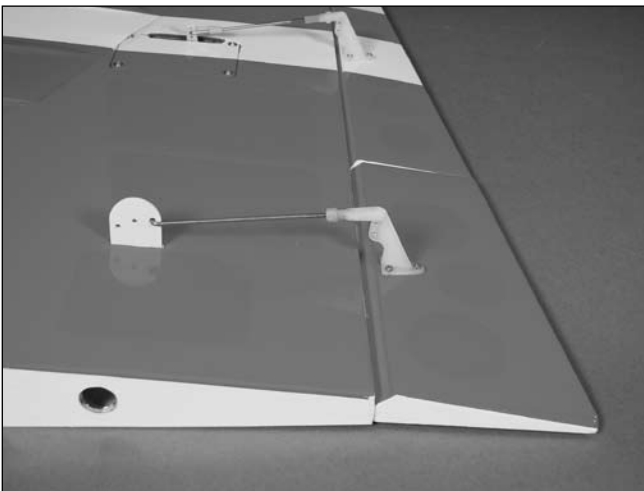

□ Step 3

Disconnect the clevis from the control horn and move the linkage to the front position. Reconnect the clevis and slide the clevis retainer into place to prevent it from opening accidentally. The flaps will now be in the full down position which is where you want them in your early flights.

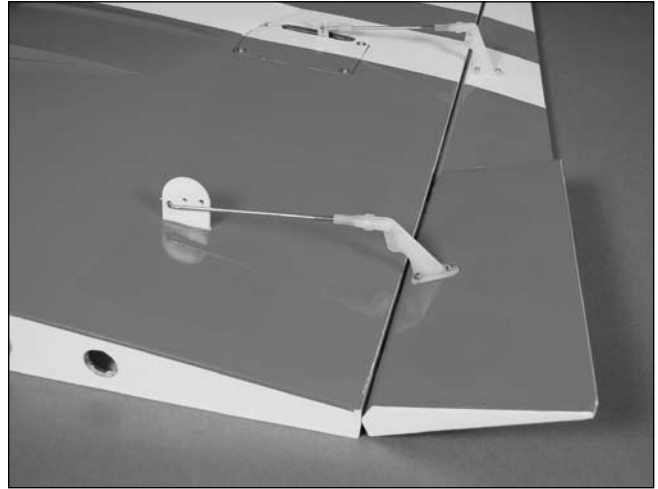

□ Step 4

Slide the short wing tube into the hole in the wing towards the leading edge. The longer wing tube slides into the hole towards the center of the wing.



Section 5: Wing Installation

□ Step 5

Slide the tubes and wing panel into the holes in the fuselage. Remove the tape from the aileron servo extension and pass it into the fuselage.



□ Step 6

Press the wing snug against the fuselage. Use the 1/4-20 x 2 1/2" nylon wing bolt to secure the wing panel to the fuselage.



□ Step 7

Pass the aileron servo extension back and under the wing tube. The connector end of the extension then goes through the servo lead retainer. The wire will fit into the notch in the retainer. Plug the connectors together and slide the retainer against the connectors to secure them together.



□ Step 8

Slide the remaining wing panel onto the tubes, remembering to guide the servo lead into the fuselage. Secure the wing panel then plug the servo extensions together.



Section 6: Centering the Control Surfaces

□ Ailerons

Check to make sure the clevis is located in the outer hole of the control horn. If not, slide the clevis retainer forward, disconnect the clevis, connect it in the correct location, and slide the clevis retainer back into position.

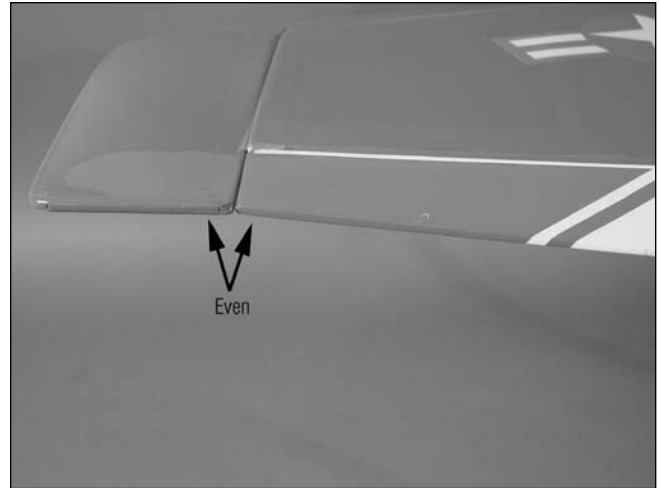
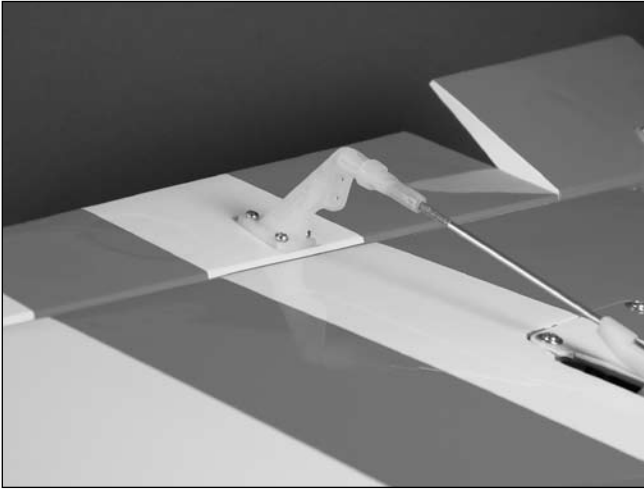

Make sure the aileron servo leads are connected as described in the previous section. Center the aileron trim on the transmitter.



Turn on the transmitter, then the receiver. Thread the clevis as necessary until the aileron is even with the wing tip.

□ Elevator

Connect the elevator clevis to the elevator control horn.



Center the trim lever for the elevator on the transmitter.



Section 6: Centering the Control Surfaces

With the radio system on, thread the clevis until the elevator is aligned with the stabilizer. Slide the clevis retainer onto the clevis to secure its location.

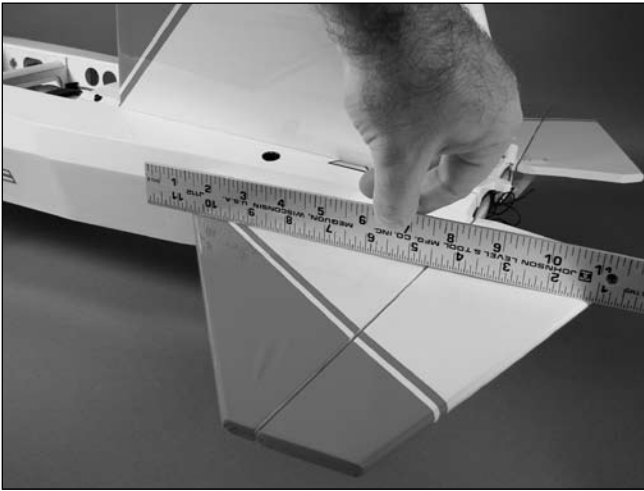

Rudder

Connect the rudder clevis to the center hole on the rudder control horn.

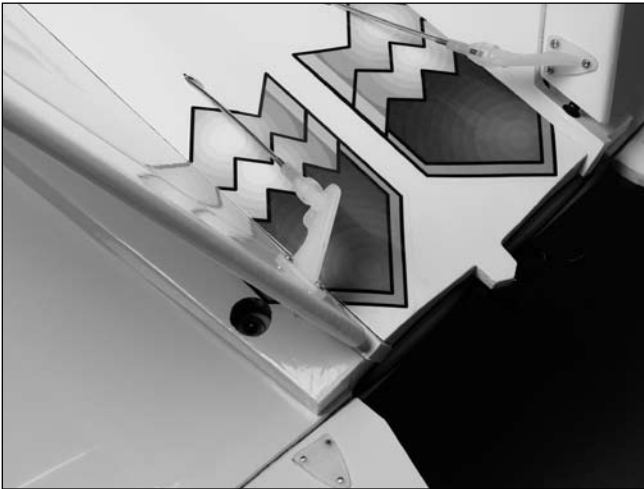

Center the trim lever for the rudder on the transmitter.



With the radio system on, thread the clevis until the rudder is aligned with the fin. Slide the clevis retainer onto the clevis to secure its location.



Section 7: Checking the Control Surface Directions

☐ Ailerons

Turn on the transmitter, then the receiver. Move the aileron stick to the right, which is the input for a right turn. The right aileron will move up, and the left aileron will move down. If not, check the radio instructions on how to reverse the direction electronically at the transmitter.

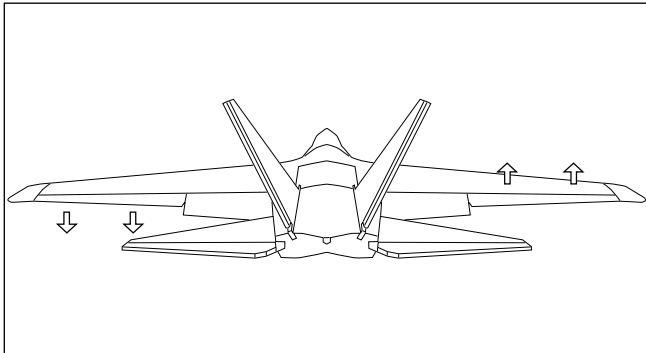

☐ Elevator

With the radio system still on, pull back on the elevator control stick to give an up elevator input. The elevator should move up from center. If not, check the radio instructions on how to reverse the direction electronically at the transmitter.

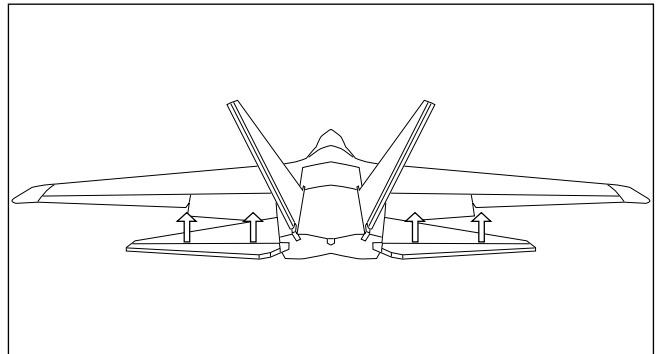

Section 7: Checking the Control Surface Directions

□ Rudder

The final control surface direction to check is the rudder. With the radio system on, move the rudder stick to the right, this will make the plane turn right. The rudders should deflect to the right as well. If not, check the radio instructions on how to reverse the direction electronically at the transmitter.

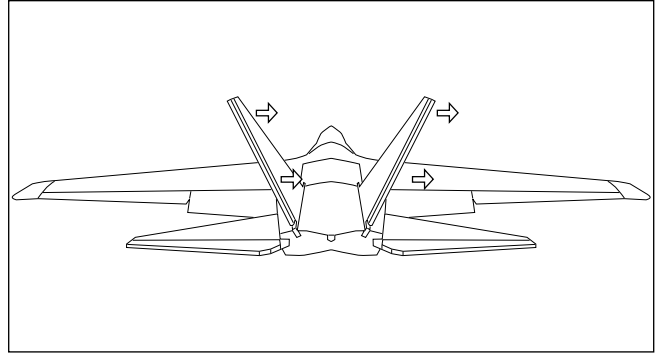

Note: Operating the functions at the transmitter opposite as described will result in the control surfaces moving opposite as well.

Section 8: Checking the Control Throw Amounts

Your F-22 PTS airplane has the correct control throws pre-programmed into your transmitter. If necessary, what follows is the method to check these appropriate control throws.

After checking that the controls are moving in the correct directions, the amount of the control movement can be checked. By moving the control stick of each surface to its full deflection, you will measure the amount the surface has moved. By holding a ruler next to the surface and establishing a reference, use the radio to make the surface move and compare the measurements to those shown.

The following photos show how to measure the control rates with the throws listed for the low rates for your F-22 Raptor.

The control throws for your F-22 are as follows:

Aileron Rate: 3/16 in (4.75mm) up and down

Note: Measure the aileron throw at the wing tip.

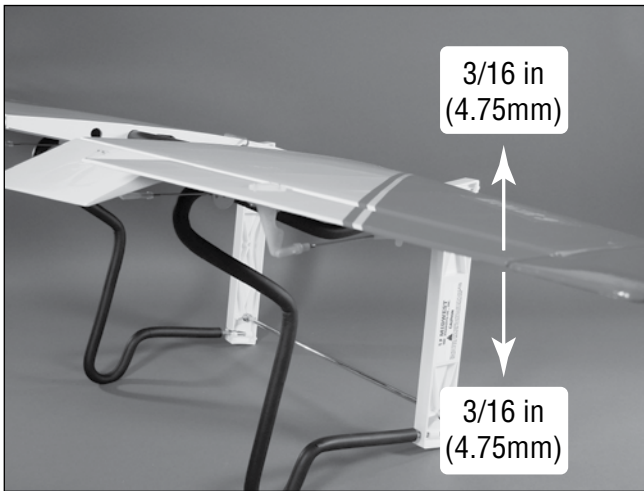

Elevator Rate: 1 1/2 in (38mm) up and down

Note: Measure the elevator throw at the widest part of the elevator.

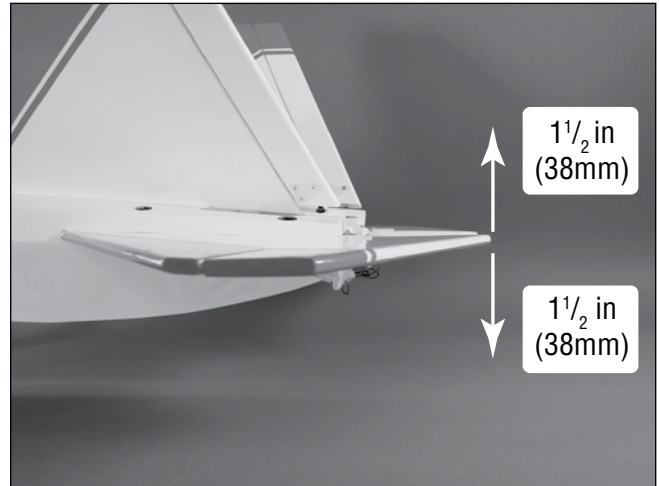

Rudder Rate: 3/8 in (9.5mm) left and right

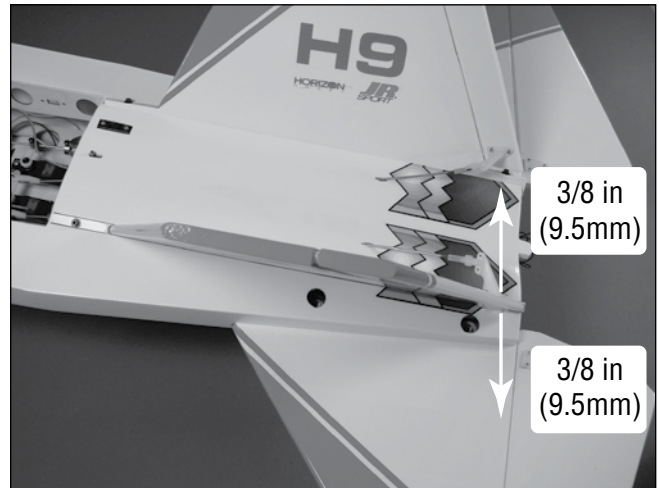

Hint: Place your ruler on a solid surface, rather than hold it in the air, to take measurements. This will guarantee your ruler is not moving. If the ruler is moving you will get inaccurate readings.

If the throws of the control surfaces are not moving the amounts as described, you may need to change the Travel Adjustment setting in the radio. To do so, read the section in the radio manual on programming the radio.

Section 9: Adjusting the Throttle

With the radio system on, move the trim lever and throttle lever towards the bottom of the transmitter. Look into the carburetor to check that the barrel is closed.

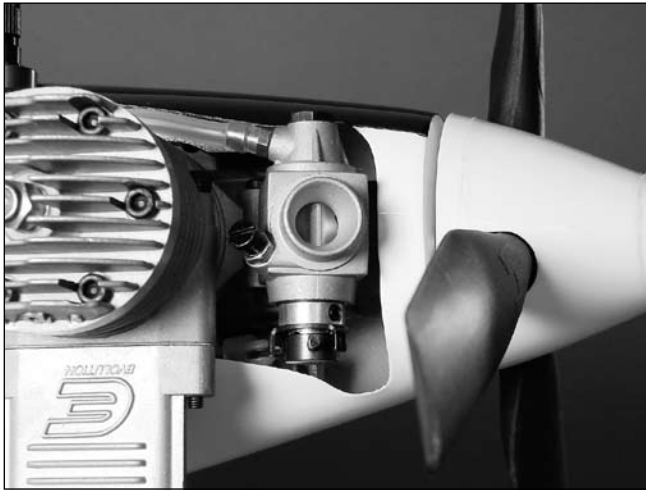

Move the trim lever up towards the top of the transmitter. The barrel in the carburetor should have an opening of around 1/16 in (1.5mm).



Move the throttle stick toward the top of the transmitter. The carburetor will now be in the fully open position.



If the throttle is not operating as described, you may need to change the Travel Adjustment setting in the radio. To do so, read the section in the radio manual on programming the radio.

Note: Once all the radio adjustments are complete, remember to turn off both the receiver and the transmitter.

Section 10: Balancing Your F-22 Raptor

In order for your F-22 Raptor PTS to fly correctly, you will need to check the balance of the plane with the fuel tank empty. This is done by supporting the aircraft either using your fingers or by using a balancing stand. Not checking the balance can result in an aircraft that is difficult to fly, which can lead to the possibility of crashing your model.

☐ Marking the Balance Point

The first step in balancing your F-22 Raptor PTS is to mark the location for the balance point. The ideal balance point for the F-22 PTS is 6 inches (152mm) back from the leading edge against the fuselage, but it can vary up to 1/4-inch (6mm) in front or behind the 6-inch mark without causing any problems. If your plane is only slightly out of balance, try placing the balancing stand towards the nose or tail by this 1/4-inch (6mm) and recheck the balance. If it looks good and sits level, then you're good to go!

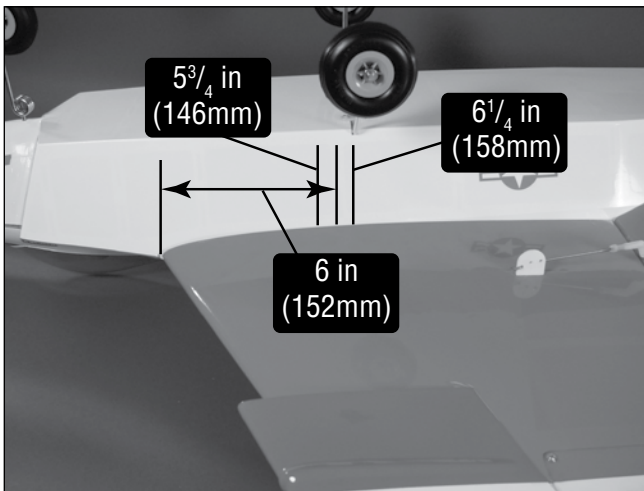

☐ Lifting the Model and Observations

Make sure the F-22 Raptor PTS is balanced using either your fingers or a balancing stand. Place or lift the airplane so it is supported at the marks made in the previous step. The plane will rest level when balanced correctly. If not, weights must be added to correct any balancing problems.

Balanced Correctly

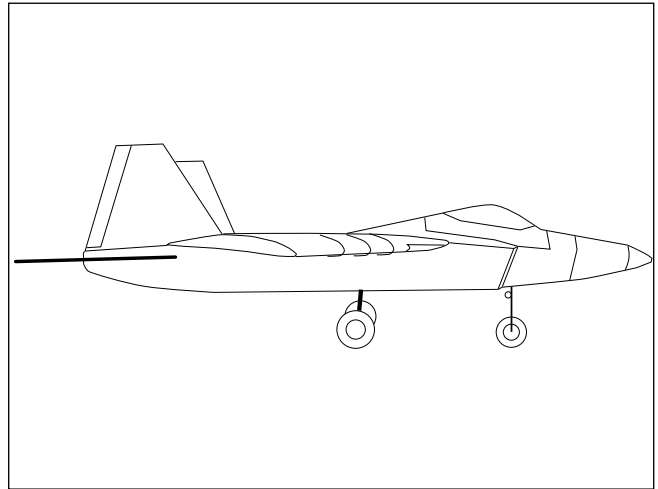

Nose Heavy – Add Weight to Tail

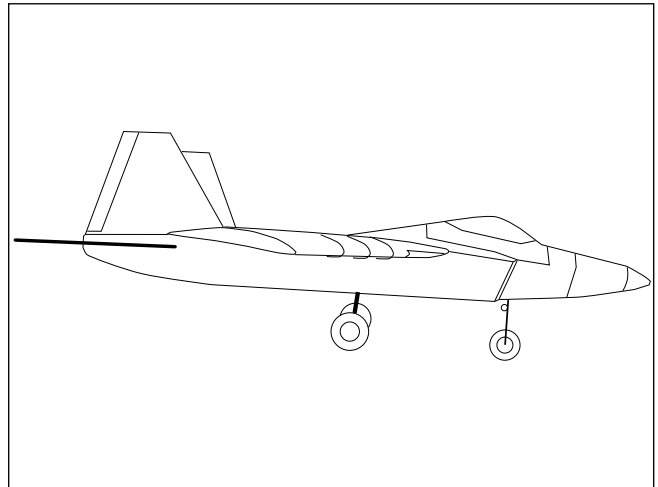

Tail Heavy – Add Weight to Nose

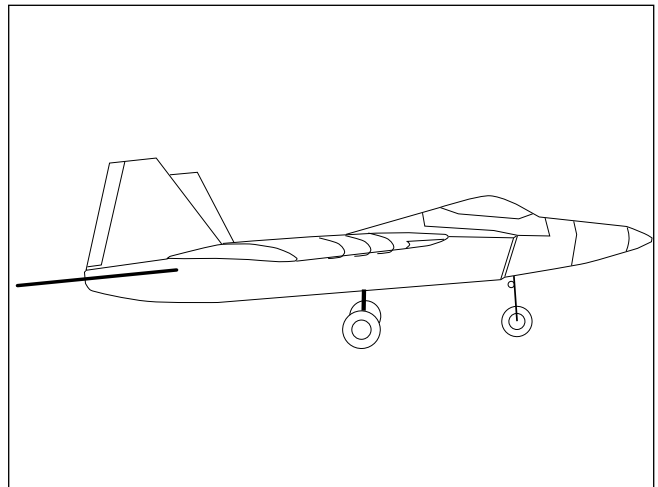

Section 10: Balancing Your F-22 Raptor

Adding Weights to Correct the Balance

Due to manufacturing differences, it is possible that the F-22 Raptor PTS may not be balanced properly. Weights can be added to either the tail or the nose of your F-22 Raptor PTS if it does not balance properly. Stick-on weights available at your local hobby store are the easiest to use, and come in sizes that are easily placed on your plane. Add just enough weight as necessary to balance your plane. Once the weight has been added, make sure it is secure and will not fall off in flight.

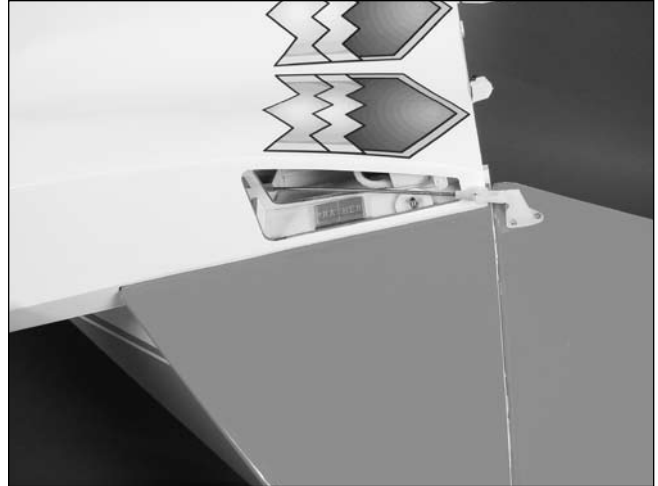
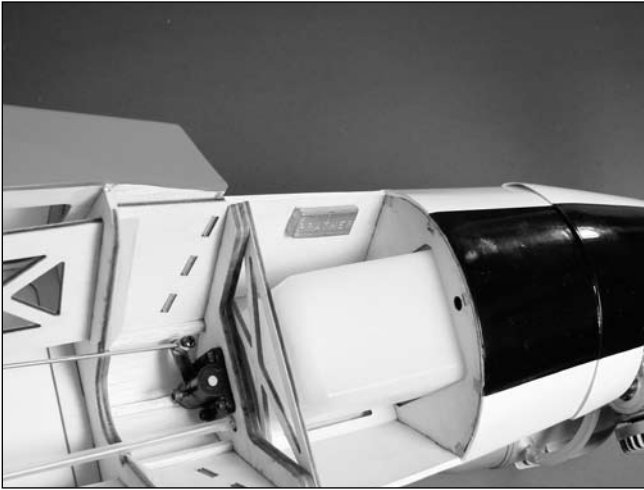

Section 11: Flight Preparations

Flight preparations are the items you must check each time you travel to the flying field. Because the F-22 Raptor PTS will encounter a variety of situations, it is best to keep an eye on the various components of your model to keep it in the best flying condition.

Checking the Frequency

When at the field, check to see if there is some form of frequency control in use. Usually there are clips each pilot will use signifying the channel their plane is flying on. This will prevent other pilots from turning on their radio systems and having more than one pilot using the same frequency. Operating two aircraft at the same time on a single frequency will lead to the demise of one or both aircraft.

Checking the Controls

Before starting your engine, check to make sure the controls are operating in the correct directions and the linkages and surfaces are not binding anywhere. Also look at the clevises and clevis retainers to make sure they are secure and will not come loose or fail in flight.

Range Check the Radio

A range check should be part of the preflight process as well. The instructions provided with your radio system will detail the correct procedure for checking the range of your particular radio system. This procedure is best done with a partner to hold your aircraft and check for any abnormalities.

Fueling the F-22 Raptor PTS

Fill the fuel tank with the proper fuel. Fill the tank by connecting the fuel pump to the line going to the needle valve. Disconnect the fuel line attached to the pressure fitting of the muffler; your tank is full when fuel begins to run out of the pressure line. Reconnect the fuel lines to the needle valve assembly and muffler.

Note: It is very important to reconnect the lines to the correct place. If they are reconnected incorrectly, the engine will not run properly.

Section 12: Maintaining Your F-22 Raptor PTS

The following is a check list that you should follow every time you have completed a flying session with your F-22 Raptor. Doing so will keep your aircraft in the best flying condition.

Clean Up

After a long flying session with your F-22 Raptor PTS, you will want to clean it up before loading it into your vehicle to head home. Use a cleaner such as Windex or 409 and a paper towel to wipe down the exterior of your plane, removing the fuel residue. Remember a clean plane will last longer since the fuel won't be allowed to soak into any exposed wood.

Checking the Propeller

Check to make sure the propeller is tightly secured to the engine. If not, remove the spinner and use a crescent wrench to tighten it back down. If you have had any not-so-great landings, you will want to inspect the propeller for any damage. Small nicks and scratches can quickly become fractures, causing the propeller to be unsafe for flight. Always carry a few spare propellers so a damaged propeller can be replaced at the field, increasing your flying time per trip to the field.

Checking the Clevises

Inspect the aileron, elevator and rudder clevises to make sure they are connected and in good working order. If you find a clevis that is showing signs of wear or is broken, replace it with a new clevis. Also check the nylon connectors at the servo for any wear or damage. If they look worn or in bad shape, replace them as well.

Checking the Control Horns

Inspect the control horns to make sure they have not crushed the wood of the control surface. If so, remove the control horn screws to remove the control horn. Place 2–3 drops of thin CA into each of the screw holes. In addition, use a T-pin to poke small holes in the covering in the area where the control horn mounts, then saturate the area with thin CA. This will harden the wood and give the control horns a solid surface to be mounted to.

Checking the Wheel Collars

Check the setscrews on the main and nose wheel collars, as well as the wheel collars on the elevator linkage, to make sure they are not loose. Use a hex wrench or Phillips screwdriver as necessary to tighten the setscrews. It is suggested if they loosen frequently to remove them, apply threadlock to the setscrews, then secure the wheel collars back into position.

Check the Muffler Bolts

Use a 2.5mm hex wrench to make sure the bolts holding the muffler onto the engine are tight and have not vibrated loose during flight.

Check the Engine Mount Bolts

Remove the spinner and propeller from the engine. Remove the exhaust stacks from the fuselage, and then remove the cowling from the fuselage. Remove the muffler from the engine, and then use a Phillips screwdriver to make sure the four bolts securing the engine to the mount are tight.

Section 13: Progressing With Your Flying Skills

Advanced

After you have mastered flying the F-22 Raptor PTS at a faster pace, the next step is to reposition the flaps. The linkage stay provides three positions for the flaps, depending on your flying skills. The photos below show the position for basic, intermediate and advanced flap positions.

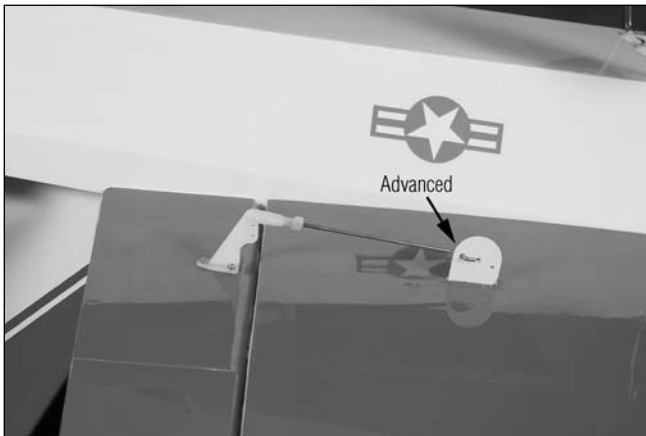
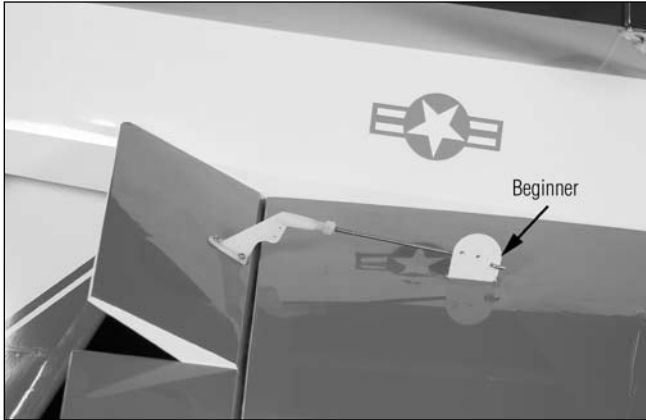

□ Step 1

Disconnect the flap linkage from the flap control horns. Remove the linkage from the linkage stay.

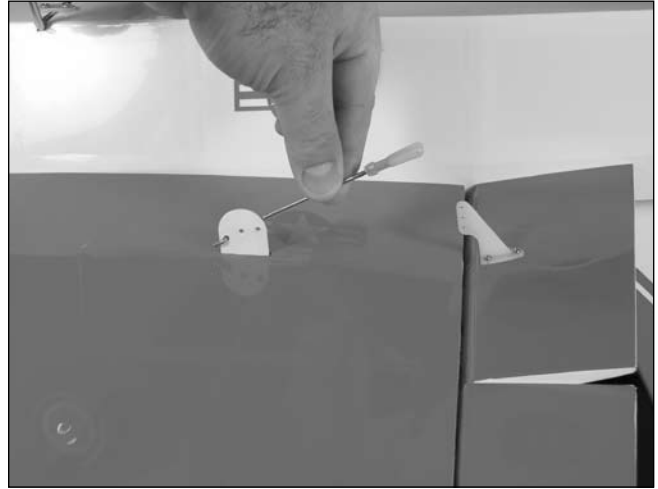

□ Step 2

Move the linkage into the new position in the flap linkage stay.

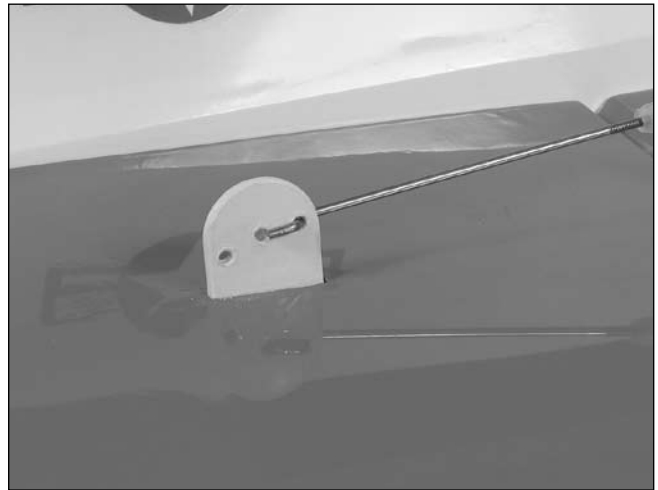

Section 13: Progressing With Your Flying Skills

□ Step 3

Reconnect the clevises and check that the flaps are in neutral, which is level with the wing center section. Check both the right and left flaps.

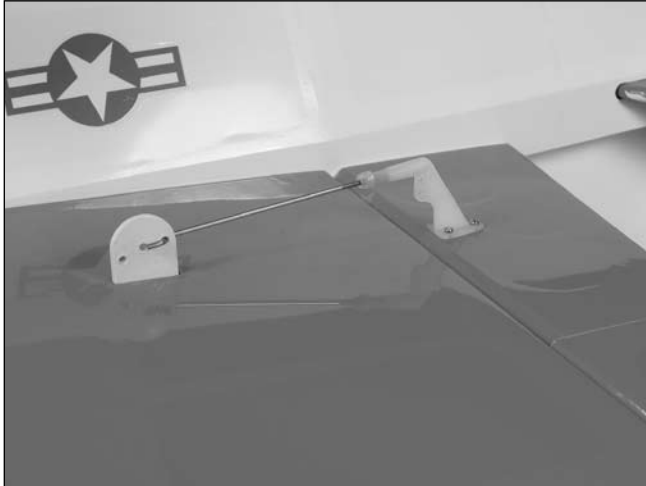

Graduate

Once you are comfortable soloing your F-22 Raptor PTS in this configuration, you're ready to graduate to advanced flight and aerobatics. The last step is to remove the anti-spin NACA droops. This is done by simply removing the tape on the top and bottom that holds them in place on the wing, along with separating the tape between the wing and droops. With the droops removed, your F-22 Raptor PTS is now an all-out aerobatic warbird. Have your instructor nearby for the first few flights. The F-22 Raptor PTS will now descend more quickly and land faster like a sport model. In the air, you can now do a variety of aerobatics such as rolls, loops, spins and snap rolls.

□ Step 1

The droops are held on with clear tape and are taped to the wing using thin double-sided tape. Pull the tape from the droops to begin the removal process.

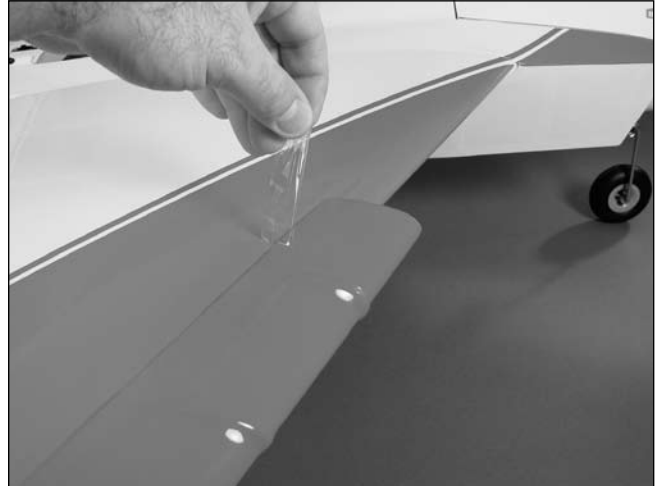

□ Step 2

Carefully separate the tape between the wing and droops starting at the inboard edge of the droops. Be careful not to damage the covering. Finally, separate the double-sided tape holding the droops to the wing tips. Save the wing droops in case you may want to use them for training a budding new pilot in the future.



Note: WD-40 does a good job in removing any remaining tape residue from your aircraft.

Section 14: Adding Flap Servos

After you have graduated from the Progressive Training System and are enjoying your F-22 Raptor PTS in its aerobatic mode, you can take it even a step further and add functional flaps. To do this, you'll need to purchase two additional servos from your local hobby store, such as the JR SPORT™ ST47 (JSP20050) servo and a Y-harness. Then, simply remove the covering over the flap servo openings in the wing panels, secure the servos to the flap servo hatches, and secure the hatches to the wing. Hook up the linkage to the servo following the directions and you have a scale F-22 Raptor complete with functioning landing flaps.

Note: Using two standard rotation servos and a standard Y-harness for the flap servos will result in them moving in opposite directions instead of the same direction. There are three options available that will result in the flaps operating correctly.

Option 1: Use two JR SPORT ST47 (JSP20050) servos and two 6-inch Servo Extensions (JSP98020) if your radio has programmable mixing. You will need to use two separate channels and use your radio to mix them together electronically for this option to work.

Option 2: Use two JR SPORT ST47 (JSP20050) servos, two 6-inch extensions and a JR® MatchBox™ or a 6" standard reversing Y-harness (EXRA320) to link the two flap servos to operate properly.

Option 3: Use a JR SPORT™ ST47 (JSP20050) standard servo and JR SPORT ST47 (JSP20050R) reverse servo and a standard Y-harness.

Items Required

- Wing (left and right)
- #2 x 3/8" screw (8)
- Servo hatch (left and right)
- 3/8 in x 3/4 in x 3/4 in (9.5mm x 19mm x 19mm) servo mounting block (4)

Tools Required

- 6-minute epoxy
- Felt-tipped pen
- Drill bit: 1/16 in (1.5mm)
- Drill
- Y-Harness (JSP98020)
- Hobby knife
- Phillips screwdriver (small)
- Razor saw
- Long Servo Arm (JRPA212) (2)

□ □ Step 1

Remove the flap linkage from the aircraft.

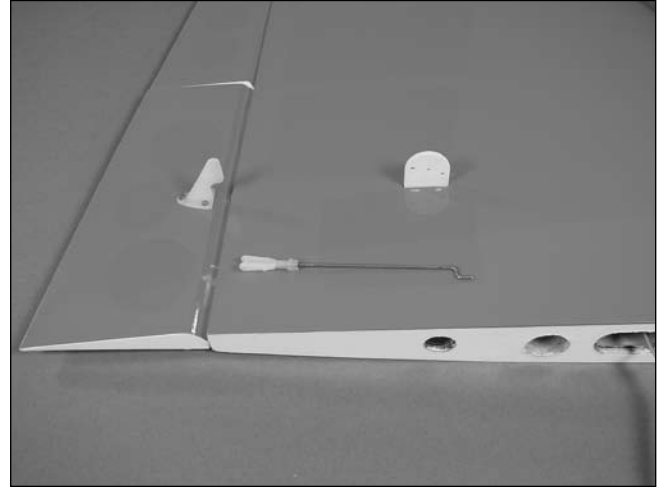

□ □ Step 2

Remove the covering from the servo opening in the bottom of the wing using a hobby knife.

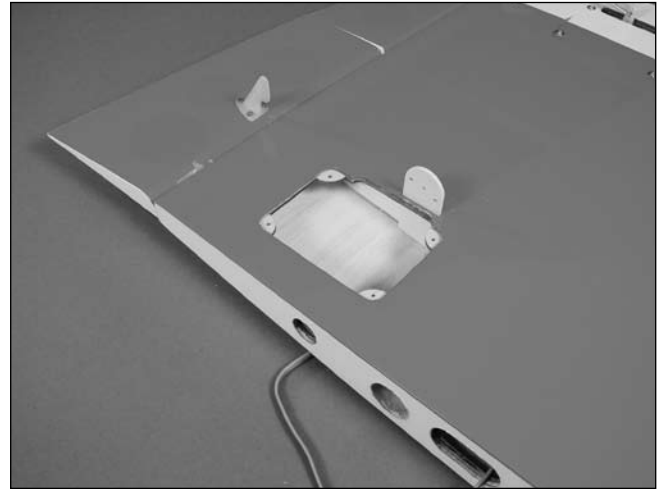

Section 14: Adding Flap Servos

□ □ Step 3

Remove the flap linkage stay from the wing. Be careful when removing the stay that you don't damage the wing. You can either use a rotary tool or razor saw to cut the tab flush with the wing.

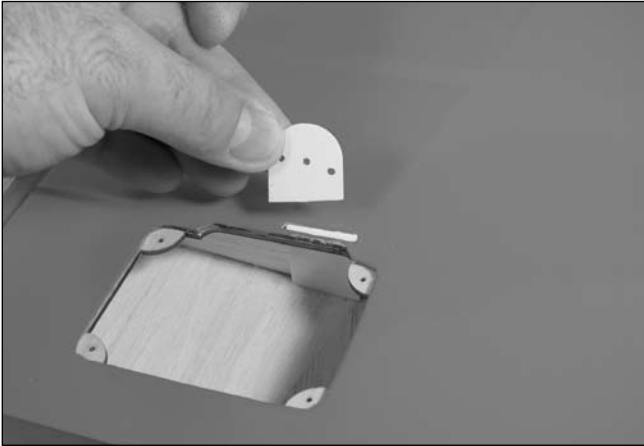

□ □ Step 4

Select the correct servo hatch by checking the alignment for the servo arm on the plate with the one on the wing.

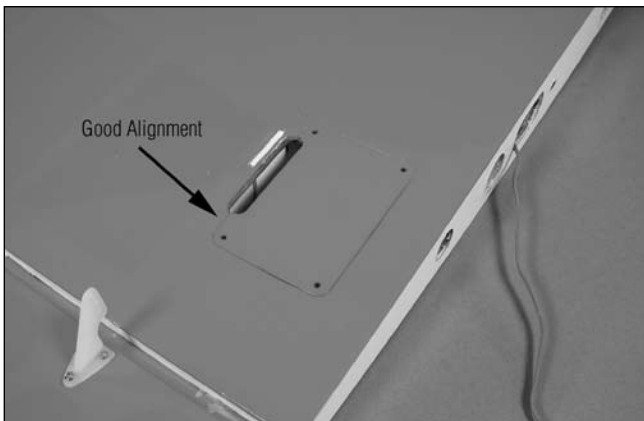
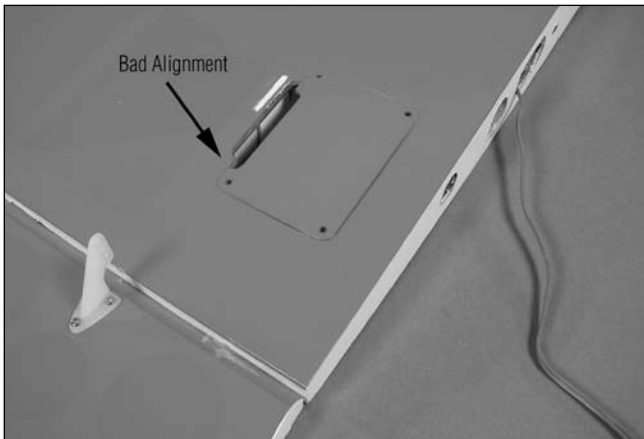

□ □ Step 5

Install the recommended servo hardware (grommets and eyelets) supplied with the servo. Temporarily install a long half servo arm (JRPA212) onto the servo and position the servo onto the hatch so the servo arm is centered in the notch. Once satisfied, mark the location for the servo mounting blocks using a felt-tipped pen.

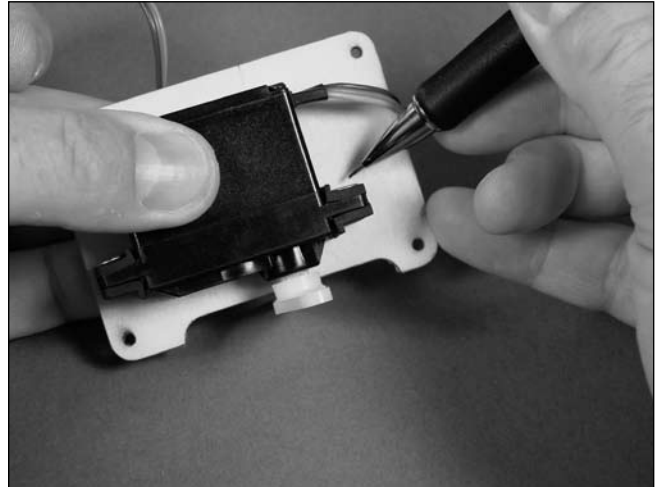

Note: Check to make sure your servo does not hang off one end of the servo hatch. If so, reposition the servo. Having the servo fully on the hatch is more important than having the servo arm centered.

□ □ Step 6

Locate two 3/8 in x 3/4 in x 3/4 in (9.5mm x 19mm x 19mm) servo mounting blocks. Use 6-minute epoxy to glue the blocks to the hatch. Let the epoxy fully cure before proceeding to the next step.

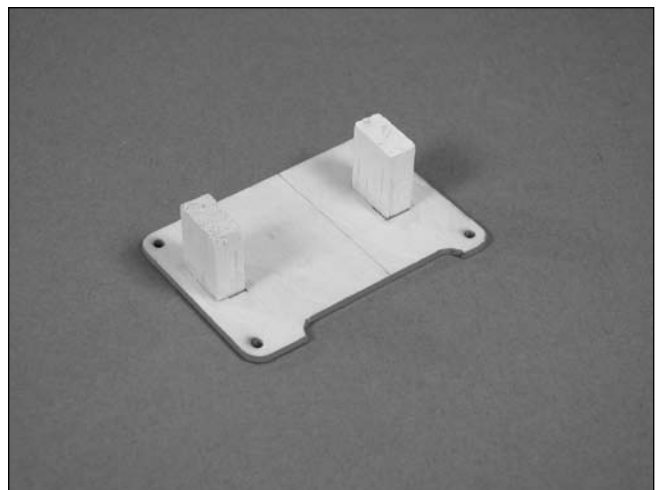

Section 14: Adding Flap Servos

□ □ Step 7

Place the aileron servo between the mounting blocks and use a felt-tipped pen to mark the location of the four servo mounting screws. Note that the servo must not touch the hatch in order to isolate engine vibration.

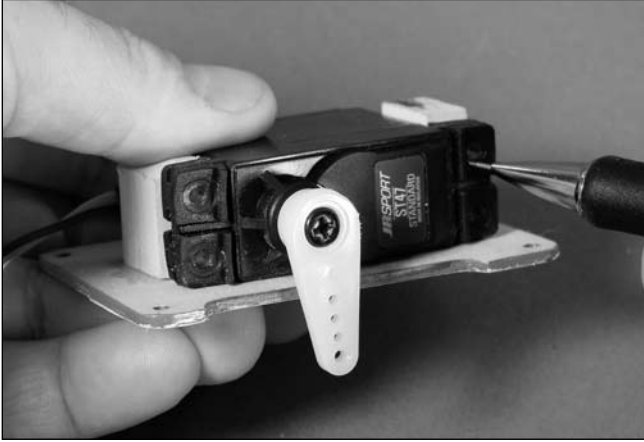

Note: Before mounting the flap servo, make sure the servo arm is installed correctly on the servo. This is done by moving the servo from each end point to determine the center position of the servo. With the radio off, secure the servo arm in the center position. Check the operation of the servo to determine if the two end positions of the arm are equal. If not, reposition the arm as necessary.

□ □ Step 8

Remove the servo and use a 1/16 in (1.5mm) drill bit to pre-drill the holes for the servo mounting screws marked in the previous step. Use the screws supplied with the servo to mount it to the servo mounting blocks.



□ □ Step 9

Pass the servo lead through the flap opening and out of the end of the wing. Secure the hatch using four #2 x 3/8" sheet metal screws.

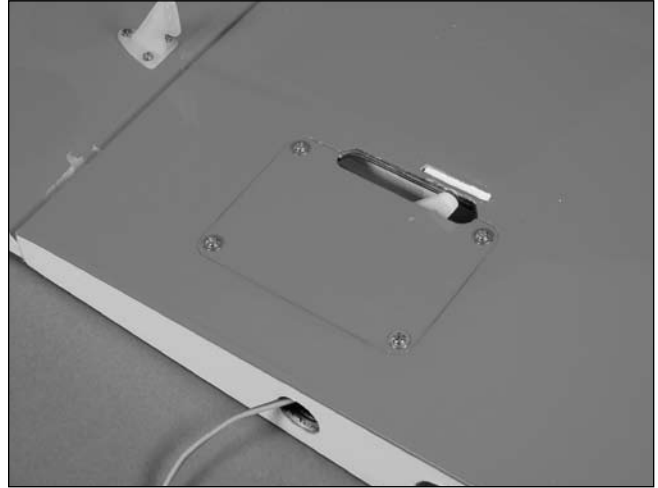

□ □ Step 10

Install the flap linkage and check the operation of the flap using the radio system. You may need to adjust the length of the linkage when the flap is in the "up" position to make sure it is fully centered.

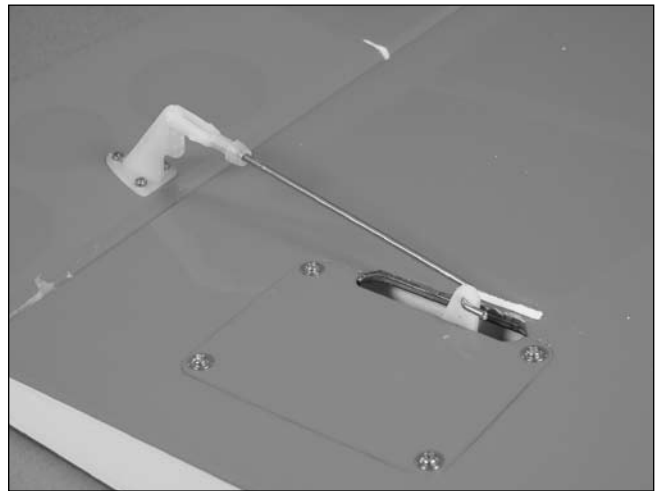

□ Step 11

Repeat Steps 1 through 10 for the remaining flap servo.

Glossary of Terms

Ailerons: Each side of this airplane has a hinged control surface (aileron), located on the trailing edge of the wing. Move the aileron stick on the transmitter left, the left aileron moves up and the right aileron moves down. Moving the left aileron up causes more drag and less lift, causing the left wing to drop down. When the right aileron moves down, more lift is created, causing the right wing to rise. This interaction causes the airplane to turn or roll to the left. Perform the opposite actions, and the airplane will roll to the right.

Clevis: The clevis connects the wire end of the pushrod to the control horn of the control surface. Being a small clip, the clevis has fine threads so that you can adjust the length of the pushrod.

Control Horn: This arm connects the control surface to the clevis and pushrod.

Dihedral: The degree of angle (V-shaped bend) at which the wings intersect the fuselage is called dihedral. More dihedral gives an airplane more aerodynamic stability. Some sailplanes and trainer planes with large dihedral dispense with ailerons and use only the rudder to control the roll and yaw.

Elevator: The hinged control surface on the back of the stabilizer that moves to control the airplane's pitch axis. Pulling the transmitter's control stick toward the bottom of the transmitter moves the elevator upward, and the airplane begins to climb. Push the control stick forward, and the airplane begins to dive.

Fuselage: The main body of an airplane.

Hinge: Flexible pieces used to connect the control surface to the flying surface. All hinges must be glued properly and securely to prevent the airplane from crashing. (This has already been done for you on the Alpha Advanced trainer.)

Horizontal Stabilizer: The horizontal flying surface of the tail gives the airplane stability while in flight.

Leading Edge: The front of a flying surface.

Main Landing Gear: The wheel and gear assembly the airplane uses to land. It is attached to the bottom of the fuselage.

Nose Gear: The part of the landing gear that is attached to the nose of the fuselage. The nose gear is usually connected to the rudder servo to help you steer the airplane on the ground.

Pitch Axis: The horizontal plane on which the airplane's nose is raised or lowered. By moving the elevator, you can raise the airplane's nose above the pitch axis (climb) or lower it below the pitch axis (dive).

Pushrod: The rigid mechanism that transfers movement from the servo to the control surface.

Roll Axis: The horizontal plane on which the airplane's wings are raised or lowered. By adjusting the ailerons, you can drop a wing tip below the roll axis and cause the airplane to bank or roll.

Rudder: The hinged control surface on the vertical stabilizer that controls the airplane's yaw. Moving the rudder to the left causes the airplane to yaw left; moving the rudder to the right causes it to yaw right.

Servo: The servo transforms your ground commands into physical adjustments of the airplane while it's in the air.

Servo Output Arm: A removable arm or wheel connecting the servo to the pushrod (also called servo horn).

Spinner: Term describing the nose cone that covers the propeller hub.

Threadlock: A liquid that solidifies; used to prevent screws from loosening due to vibration.

Torque Rods: Inserted into the ailerons, these rigid wire rods run along the wing's trailing edge, then bend downward and connect to the pushrod.

Vertical Stabilizer: The vertical flying surface of the tail gives the airplane stability while in flight.

Wheel Collar: The round, metal retaining piece that anchors wheels in place on the wheel axle.

Wing: The lifting surface of an airplane.

Yaw Axis: The vertical plane through which the airplane's nose rotates as it yaws to the left or to the right. The rudder controls the yaw axis.

2007 Official AMA National Model Aircraft Safety Code

GENERAL

1) I will not fly my model aircraft in sanctioned events, air shows or model flying demonstrations until it has been proven to be airworthy by having been previously, successfully flight tested.

2) I will not fly my model higher than approximately 400 feet within 3 miles of an airport without notifying the airport operator. I will give right-of-way and avoid flying in the proximity of full-scale aircraft. Where necessary, an observer shall be utilized to supervise flying to avoid having models fly in the proximity of full-scale aircraft.

3) Where established, I will abide by the safety rules for the flying site I use, and I will not willfully and deliberately fly my models in a careless, reckless and/or dangerous manner.

4) The maximum takeoff weight of a model is 55 pounds, except models flown under Experimental Aircraft rules.

5) I will not fly my model unless it is identified with my name and address or AMA number, on or in the model. (This does not apply to models while being flown indoors.)

6) I will not operate models with metal-bladed propellers or with gaseous boosts, in which gases other than air enter their internal combustion engine(s); nor will I operate models with extremely hazardous fuels such as those containing tetranitromethane or hydrazine.

7) I will not operate models with pyrotechnics (any device that explodes, burns, or propels a projectile of any kind) including, but not limited to, rockets, explosive bombs dropped from models, smoke bombs, all explosive gases (such as hydrogen-filled balloons), or ground mounted devices launching a projectile. The only exceptions permitted are rockets flown in accordance with the National Model Rocketry Safety Code or those permanently attached (as per JATO use); also those items authorized for Air Show Team use as defined by AST Advisory Committee (document available from AMA HQ). In any case, models using rocket motors as a primary means of propulsion are limited to a maximum weight of 3.3 pounds and a G series motor. (A model aircraft is defined as an aircraft with or without engine, not able to carry a human being.)

8) I will not consume alcoholic beverages prior to, nor during, participation in any model operations.

9) Children under 6 years old are only allowed on the flight line as a pilot or while receiving flight instruction.

RADIO CONTROL

1) I will have completed a successful radio equipment ground range check before the first flight of a new or repaired model.

2) I will not fly my model aircraft in the presence of spectators until I become a qualified flier, unless assisted by an experienced helper.

3) At all flying sites a straight or curved line(s) must be established in front of which all flying takes place with the other side for spectators. Only personnel involved with flying the aircraft are allowed at or in the front of the flight line. Intentional flying behind the flight line is prohibited.

4) I will operate my model using only radio control frequencies currently allowed by the Federal Communications Commission. (Only properly licensed Amateurs are authorized to operate equipment on Amateur Band frequencies.)

2007 Official AMA National Model Aircraft Safety Code

- 5) Flying sites separated by three miles or more are considered safe from site-to site interference, even when both sites use the same frequencies. Any circumstances under three miles separation require a frequency management arrangement, which may be either an allocation of specific frequencies for each site or testing to determine that freedom from interference exists. Allocation plans or interference test reports shall be signed by the parties involved and provided to AMA Headquarters. Documents of agreement and reports may exist between (1) two or more AMA Chartered Clubs, (2) AMA clubs and individual AMA members not associated with AMA Clubs, or (3) two or more individual AMA members.
- 6) For Combat, distance between combat engagement line and spectator line will be 500 feet per cubic inch of engine displacement. (Example: .40 engine = 200 feet.); electric motors will be based on equivalent combustion engine size. Additional safety requirements will be per the RC Combat section of the current Competition Regulations.
- 7) At air shows or model flying demonstrations, a single straight line must be established, one side of which is for flying, with the other side for spectators.
- 8) With the exception of events flown under AMA Competition rules, after launch, except for pilots or helpers being used, no powered model may be flown closer than 25 feet to any person.
- 9) Under no circumstances may a pilot or other person touch a powered model in flight.

Organized RC Racing Event

- 10) An RC racing event, whether or not an AMA Rule Book event, is one in which model aircraft compete in flight over a prescribed course with the objective of finishing the course faster to determine the winner.
 - A. In every organized racing event in which contestants, callers and officials are on the course:
 1. All officials, callers and contestants must properly wear helmets, which are OSHA, DOT, ANSI, SNELL or NOCSAE approved or comparable standard while on the racecourse.
 2. All officials will be off the course except for the starter and their assistant.
 3. "On the course" is defined to mean any area beyond the pilot/staging area where actual flying takes place.
 - B. I will not fly my model aircraft in any organized racing event which does not comply with paragraph A above or which allows models over 20 pounds unless that competition event is AMA sanctioned.
 - C. Distance from the pylon to the nearest spectator (line) will be in accordance with the current Competition Regulations under the RC Pylon Racing section for the specific event pending two or three pylon course layout.
- 11) RC night flying is limited to low-performance models (less than 100 mph). The models must be equipped with a lighting system that clearly defines the aircraft's position in the air at all times.



© 2007 Horizon Hobby, Inc.
4105 Fieldstone Road
Champaign, Illinois 61822
(877) 504-0233
www.horizonhobby.com